

INTRODUCING D-BOX G5, OUR LATEST GENERATION OF HIGH-FIDELITY HAPTIC ACTUATORS!

Featuring a completely new form factor as well as simpler infrastructure and simpler connections, G5 offers all the benefits you have come to know and love from D-BOX in terms of performance, realism and reliability, but now in an all-new package ready to make the operation and installation of our systems easier than ever before! Gone are the days of multiple large ACM boxes, as our new "haptic bridge" gathers the data of up to 4 actuators in a single control box that is significantly smaller and sleeker than our previous design. With voltage selection included in every individual actuator, you can seamlessly go between 110V and 230V with the flick of a switch... Making G5 a much more flexible solution!

PERFORMANCE UNDER MAXIMUM LOAD

MAXIMUM LIFTING CAPACITY	250 lb / 114 kg
HORIZONTAL LOAD	Translation on limited friction surfaces can be done on weights up to 3 times vertical lifting capacity.
MAXIMUM STROKE	1.5 inch / 38.1 mm
MAXIMUM VELOCITY	100 mm/s
MAXIMUM ACCELERATION	+/- 1 g-force
FREQUENCY RANGE	0-100 Hz
OPERATING TEMPERATURE RANGE	0-40 °C
OPERATING HYGROMETRY	10 to 85 % (free from condensing)

POWER REQUIREMENTS		AVERAGE POWER To be used for electric consumption (Watts)	AVERAGE POWER To be used for converter specification (VA)	PEAK CURRENT To be used for breaker specification (A)
120 V 50/60 HZ	1 ACTUATOR	150 W	240 VA	2 A
	2 ACTUATORS	270 W	470 VA	4 A
	3 ACTUATORS	420 W	710 VA	6 A
	4 ACTUATORS	540 W	940 VA	8 A
230 V 50/60 HZ	1 ACTUATOR	150 W	260 VA	1.1 A
	2 ACTUATORS	270 W	480 VA	2.1 A
	3 ACTUATORS	420 W	740 VA	3.2 A
	4 ACTUATORS	540 W	960 VA	4.2 A

Note: It is not recommended to connect your D-BOX system to a GFCI breaker type.

G5 COMPONENTS

WEIGHT

HAPTIC ACTUATOR G5 - HA201 (M1-250 AC218 63")	9.2 lbs / 4.17 kg
HAPTIC BRIDGE G5 - HB140 (USB)	0.6 lbs / 0.27 kg
HAPTIC BRIDGE G5 - HB240 (USB & KINECHAIN)	1.0 lbs / 0.45 kg
CAPTIVE ENDING, AC218, 1 AXIS O330, W SPACER RETAINER	5.8 lbs / 2.63 kg
CAPTIVE ENDING, AC218, 2 AXIS O563, W SPACER RETAINER	5.4 lbs / 2.45 kg
CAPTIVE ENDING, PILLOW BLOCK 25MM, AC218, 1 AXIS, W ROTULE ANCHOR	1.4 lbs / 0.63 kg

System overview*

BRACKET OPTIONS

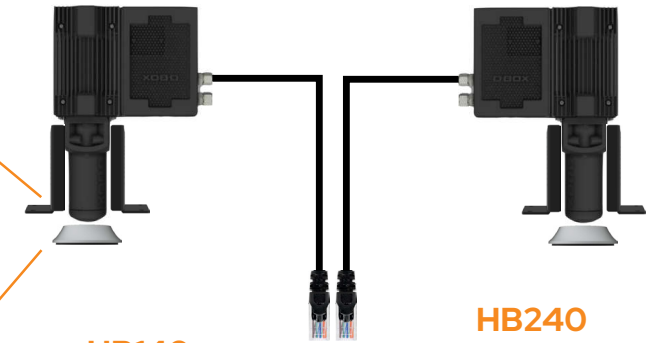
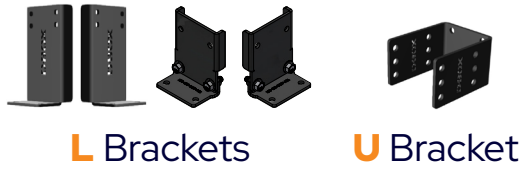

ENDING OPTIONS

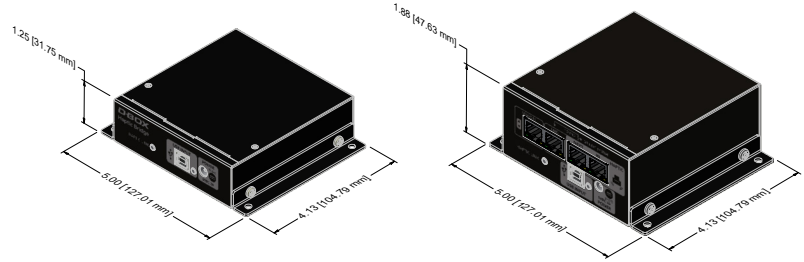

* Two Haptic Actuator System.

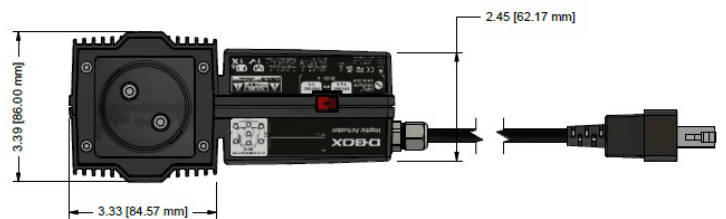
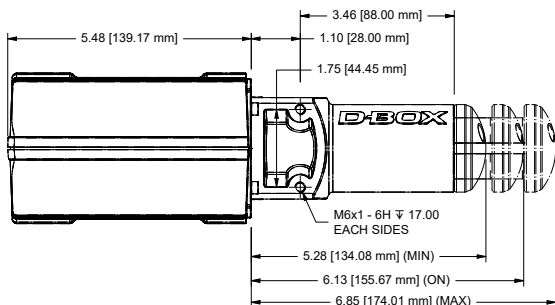
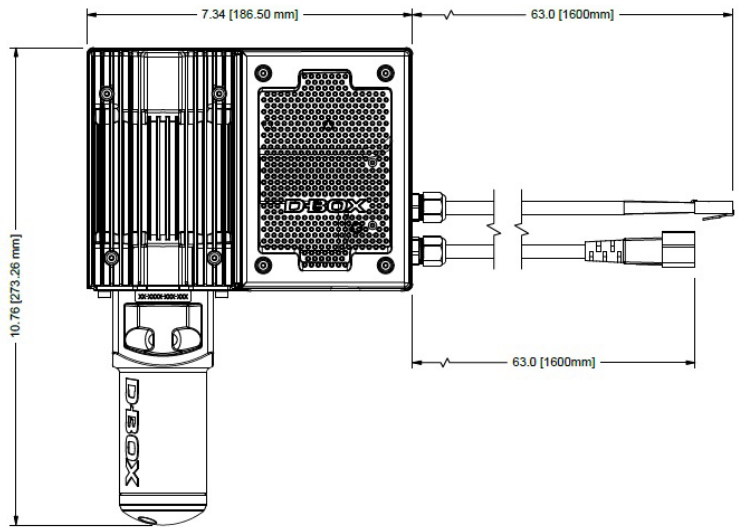
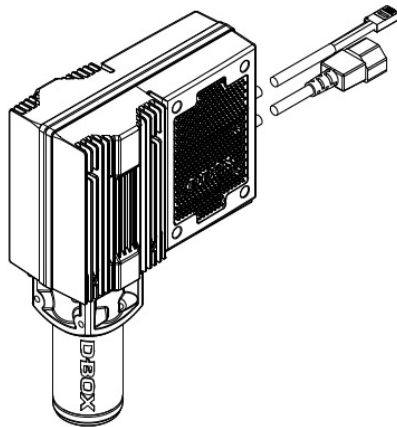

Complete CAD drawings available on demand. Please contact D-BOX Support.